

REVISION HISTORY			
REV	DESCRIPTION	DATE	APPROVED
0	DRAWN ON CAD	03/15/10	

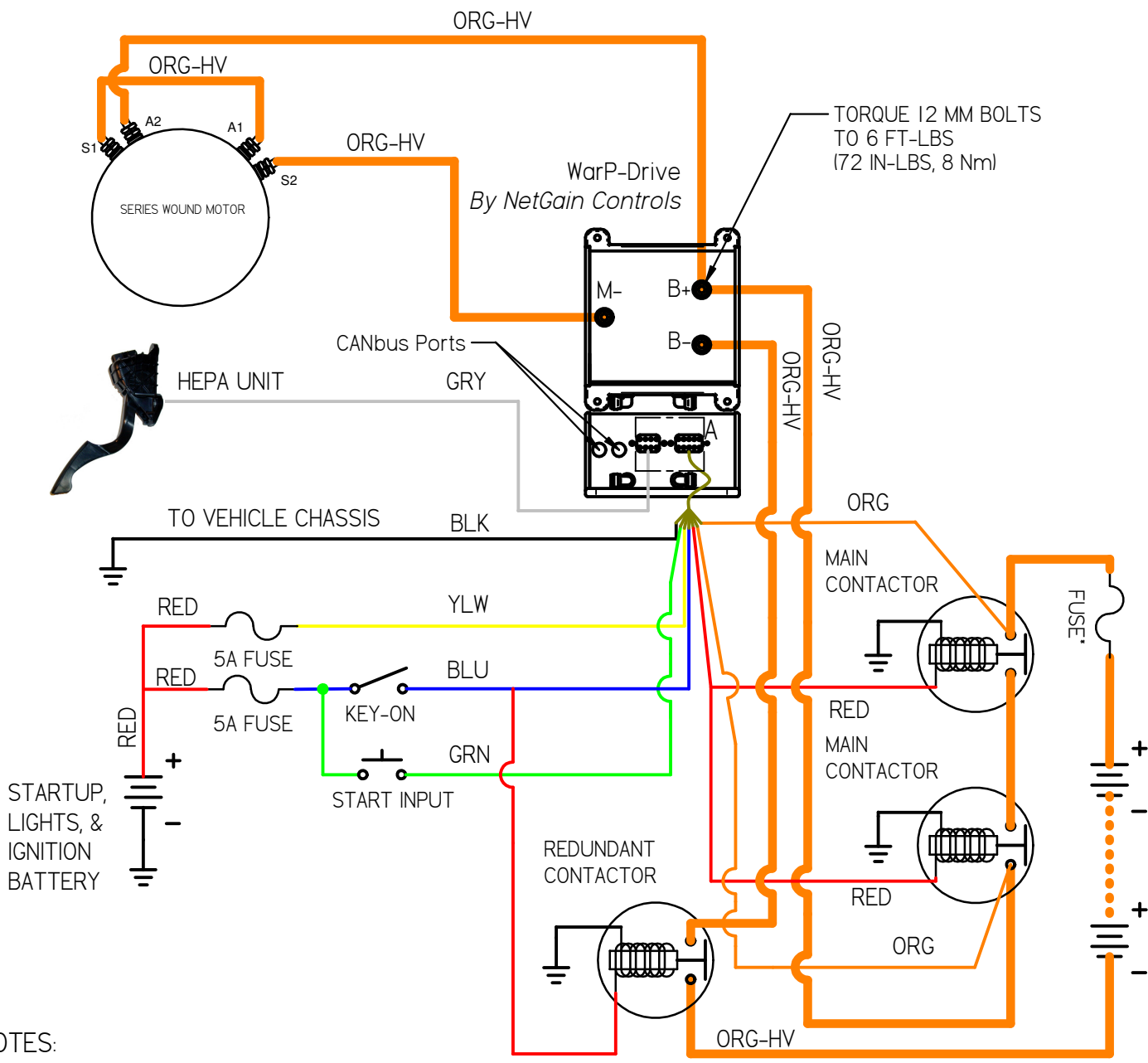

TORQUE 12 MM BOLTS TO 6 FT-LBS (72 IN-LBS, 8 Nm)

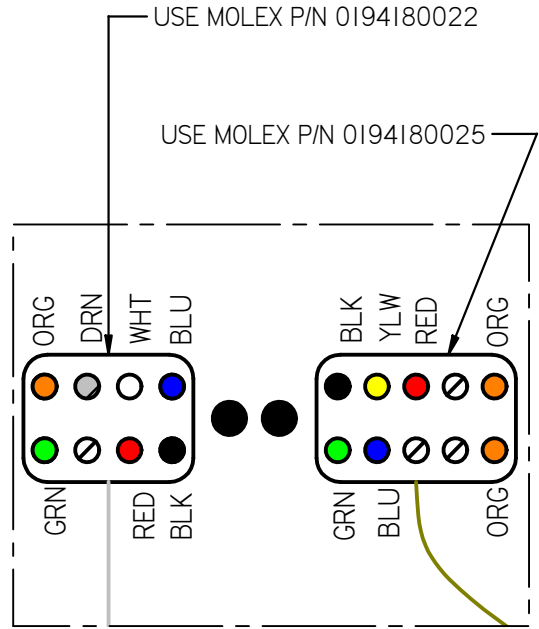

DETAIL A

NOTES:  
 1. HV = High Voltage Wire  
 2. Orange Wires on 10 pin connector are not polarity sensitive  
 3. Motor Wiring is based on NetGain WarP series motors recommended connection method. For full documentation, visit [www.go-ev.com](http://www.go-ev.com)  
 Recommended Fuse: Ferraz Shawmut A30QS500-4

DRAWN	FRED	DATE	03/15/10	NetGain Controls, Inc.
CHECKED	RYAN			
PLOT DATE	03/15/10			
THIS DRAWING IS THE PROPERTY OF NETGAIN CONTROLS, INC AND IS NOT TO BE USED FOR ANY PURPOSE OTHER THAN THAT FOR WHICH IT WAS SPECIFICALLY FURNISHED				TITLE WarP-Drive Wiring Diagram SIZE A PART NO. (PART NO.) WarP-Drive_Wiring_Schematic_3.dft SCALE WEIGHT:
				REV 0