

ON ROAD MOTOR SPEED CONTROLLERS



CURTIS

MODELS 1231C/1221C



DESCRIPTION

The Curtis PMC models 1231C and 1221C motor speed controllers provide smooth, silent, efficient and cost effective speed control for on-road electric vehicle applications. These controllers utilize power MOSFET technology, pioneered by Curtis PMC, to provide benefits unavailable with older speed control systems.

APPLICATION

The Curtis PMC models 1231C and 1221C are high power, heavy duty MOSFET electronic motor speed controllers which are ideal for use in electric commuter vehicles, light delivery trucks, and other vehicles utilizing up to 144 volts.

FEATURES

- High frequency switching and ultra low voltage drop provides very high efficiency and quiet operation. Costs, heatsinking requirements and motor and battery losses are reduced. Low end torque, range and battery life are increased.
- Environmental protection provided by a sealed (factory serviceable), rugged, anodized aluminum extrusion housing. Simple mounting and wiring with push-on type connectors for control signals. Plated solid copper busses used for all power connections.
- Thermal protection and compensation circuit provides under-temperature cutback, constant current limit over operating range, and linear rollback in over-temperature. No sudden loss of power under any thermal conditions.
- Frequency shifting from 15 kHz to 1.5 kHz at low throttle settings provides improved protection against stalled motors.
- Heavy duty power base in 1231C contains additional active devices to improve power handling capability.
- Potentiometer fault protection circuitry disables the controller if the throttle wires become open.
- High Pedal Disable prevents controller operation if the key switch is turned on while throttle is applied.
- Optional heatsink (p/n 16286) for model 1231C controller improves thermal capability.
- No adjustments are required.
- Simple installation — Uses a two wire throttle potentiometer.

SPECIFICATIONS

- Frequency of Operation: 15/1.5 kHz
- Standby Current: less than 30 mA
- Ambient Operating Temperature Range: -25°C to 50°C
- Controller Temperature Cutback Point: -25°C and +85°C

CURTIS INSTRUMENTS, INC.

200 KISCO AVENUE
MT. KISCO, NY 10549
USA
TEL (914) 666-2971
FAX (914) 666-2188

235 EAST AIRWAY BLVD.
LIVERMORE, CA 94551
USA
TEL (925) 961-1088
FAX (925) 961-1099

CURTIS INSTRUMENTS, (UK) LTD.

5 UPPER PRIORY STREET
NORTHAMPTON NN1 2PT
ENGLAND
TEL 44 (0) 1604-629755

CURTIS INSTRUMENTS INDIA PRIVATE LTD.

1199, GHOLE ROAD
PUNE 411004, INDIA
TEL 91 (0) 20-5531288
FAX 91 (0) 20-5539192

MODELS 1231C/1221C

MODEL CHART

CURTIS PMC MODELS	VOLTAGE (volts)	CURRENT (amps)	2 MIN RATING (amps)	5 MIN RATING (amps)	1 HOUR RATING (amps)	VOLTAGE DROP @ 100A	UNDERVOLT CUTBACK (volts)
1231C-86XX	96-144	500	500	375	225	.30	64
1231C-77XX	72-120	550	550	375	225	.30	43
1221C-74XX	72-120	400	400	250	150	.50	43

DIMENSIONS 1231

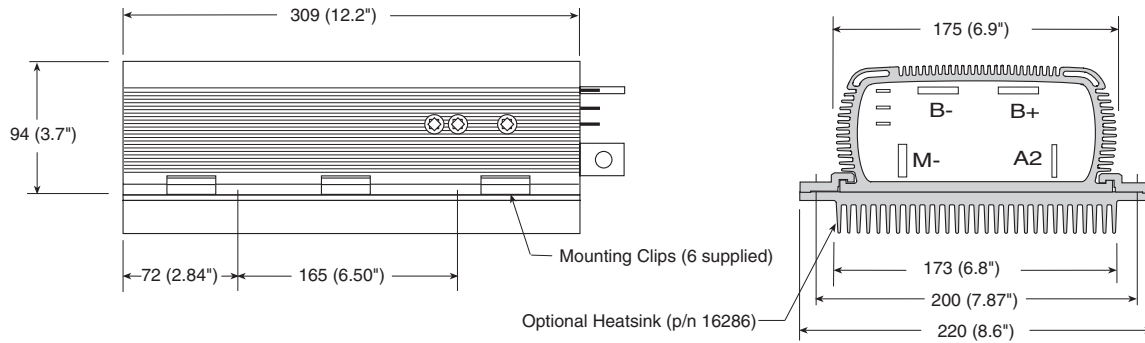

DIMENSIONS 1221

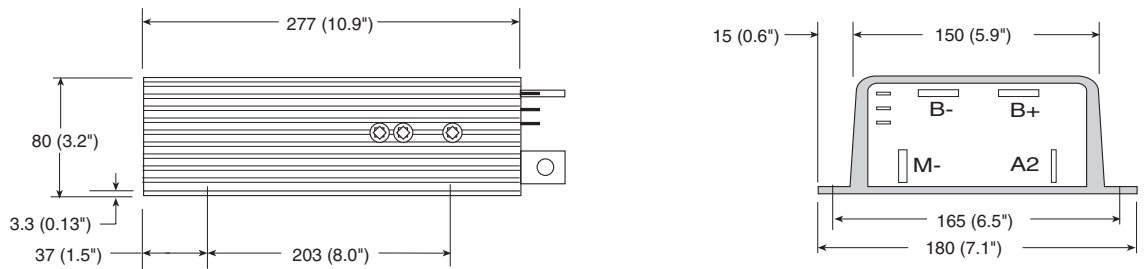

TYPICAL WIRING DIAGRAM

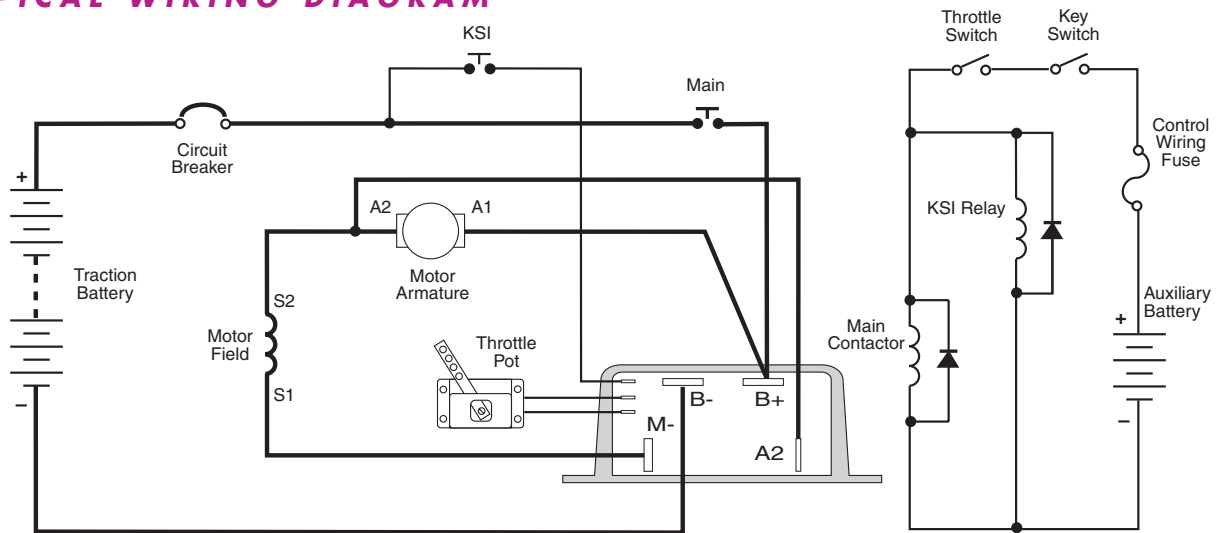

WARRANTY Two year limited warranty from time of delivery.

